



MANUFACTURERS OF SPECIALIST TEST EQUIPMENT

# Sphere Gap Test Apparatus

For EN60052 Compliant High-Voltage Testing

## **Assembly, calibration and operating instructions**

Please read this manual before using the equipment

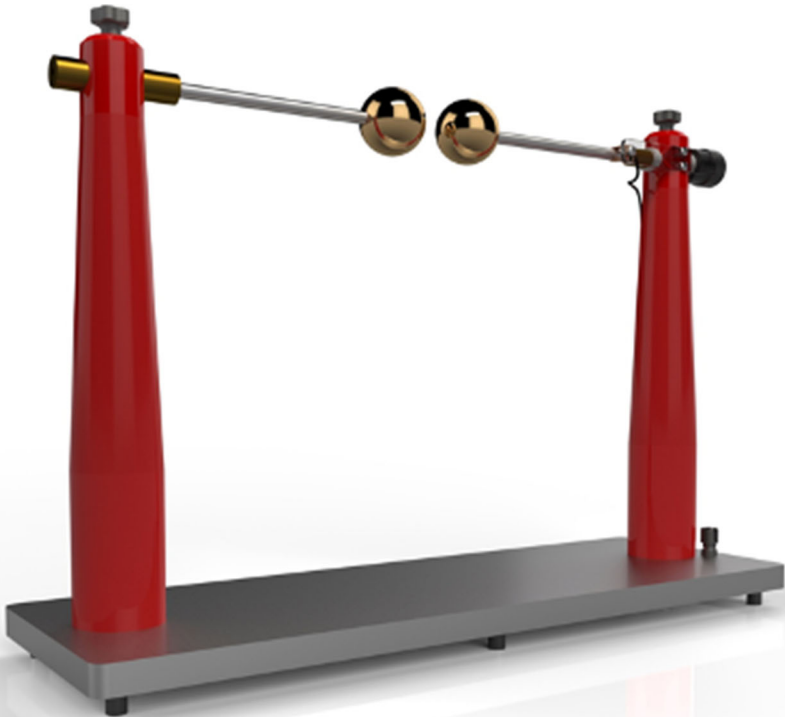



---

# Contents

|                              |    |
|------------------------------|----|
| Contents .....               | 3  |
| Overview.....                | 4  |
| Specifications.....          | 4  |
| Testing principle .....      | 4  |
| Safety Warnings .....        | 5  |
| Tools required .....         | 6  |
| Unpacking and assembly ..... | 6  |
| Unpacking.....               | 6  |
| Calibration.....             | 15 |
| Adjustment .....             | 19 |
| Electrical Connection.....   | 21 |
| Product Registration .....   | 22 |
| Manufacturer .....           | 24 |
| Distributor .....            | 24 |

# Overview

## Specifications

|                        |                       |
|------------------------|-----------------------|
| Dimensions:            | 600mm x 430mm x 200mm |
| Weight:                | 10.4kg                |
| Minimum test gap:      | <0.01mm               |
| Gap measurement range: | 17mm                  |
| Sphere diameter:       | 50.8mm                |
| Sphere material:       | Non-ferrous           |
| Accuracy:              | +/-0.1mm              |
| Electrical connection: | 4mm banana plug       |

## Testing principle

The use of Sphere Gap Apparatus is an internationally accepted and standardised method by which the distance a spark can jump in air between two spherical electrodes is used to measure high voltages.

This apparatus has been designed and manufactured for use in accordance with **EN 60052 Voltage Measurement By Means Of Standard Air Gaps**.

We strongly advise that all tests using this apparatus are undertaken with reference to, and an understanding of, the latest version of **EN 60052**.

# Safety Warnings

A high-voltage will always take the easiest route to earth. The risk of electrical shock is inherent when operating, repairing or testing high-voltage equipment and extreme caution must be taken at all times.



**IMPORTANT:** We strongly advise that individuals with pacemakers, cochlear implants or trans-dermal electronic implants - e.g. glucose monitors do not use our high-voltage test equipment under any circumstances.



**IMPORTANT:** This product must not be used in combustible atmospheres or ATEX Hazardous Areas, such as fuel stations or in proximity to any combustible gas (and/ or oxygen concentrations exceeding normal atmosphere).



**IMPORTANT:** This instrument must be connected to an appropriate earth (ground) before a high voltage is applied.



All high-voltage testing equipment must be operated by suitably trained, responsible, authorised personnel only.



Observe all safety precautions; operators will be exposed to high voltages when using this instrument. Avoid contact with live components.

## Tools required

The following tools are required to assemble and calibrate the apparatus



**No.2 Pozidrive screwdriver**



**8mm Allen key**

## Unpacking and assembly

### Unpacking

Remove all items from the packaging and ensure all components shown below are present and undamaged.



**A) Alignment Rod – dia 20mm**



**B) Main chassis/stand**



C) Live side post and thumbscrew



D) Earth-side post and thumbscrew

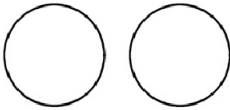

E) Non-ferrous sphere x2



F) M4 x 50mm post retaining screw x2



G) Ground-side spindle assembly



H) M4 x 10mm post retaining screws

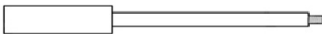

I) Live Side Spindle Assembly



J) Cable tie x2

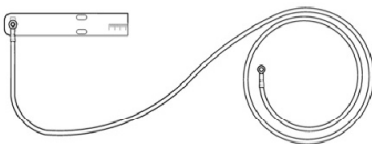

K) Gauge and conductor brush assembly

### Assembly

1

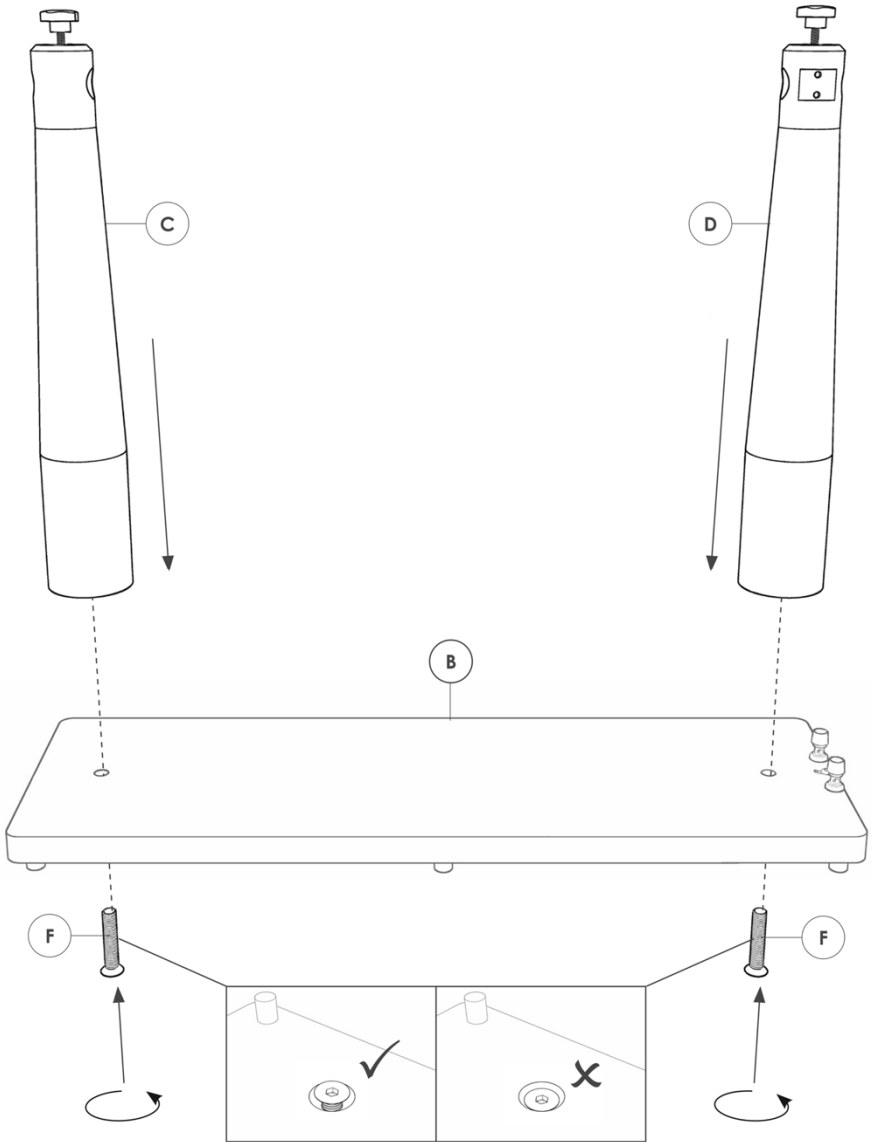



2

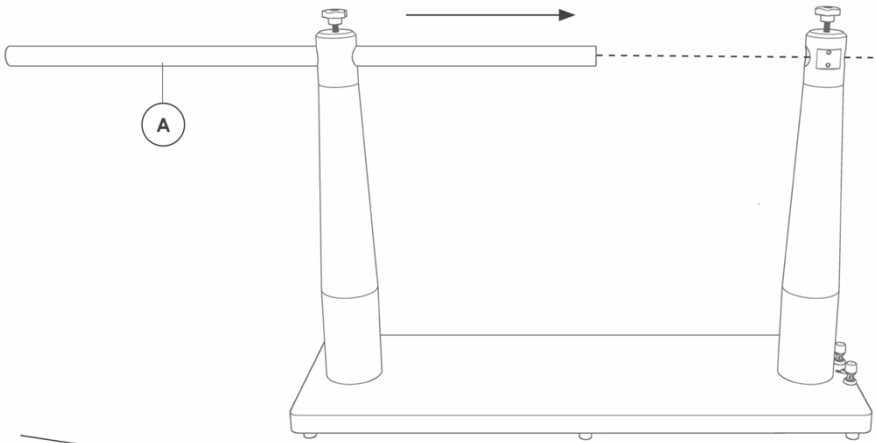

3

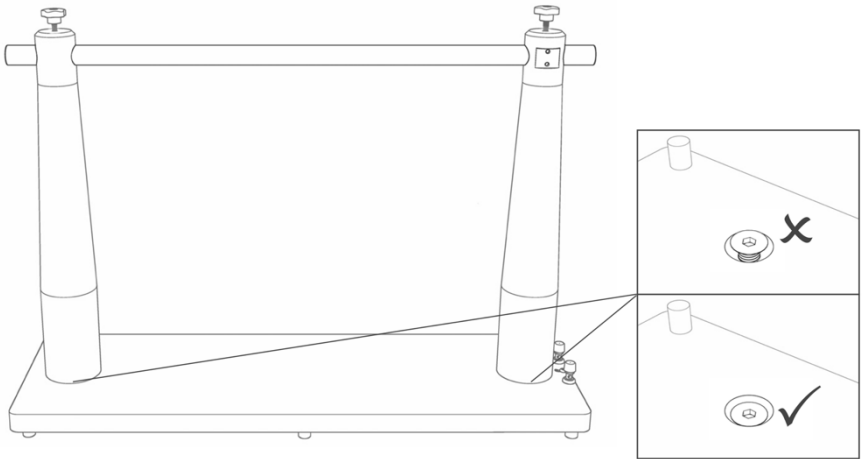

4

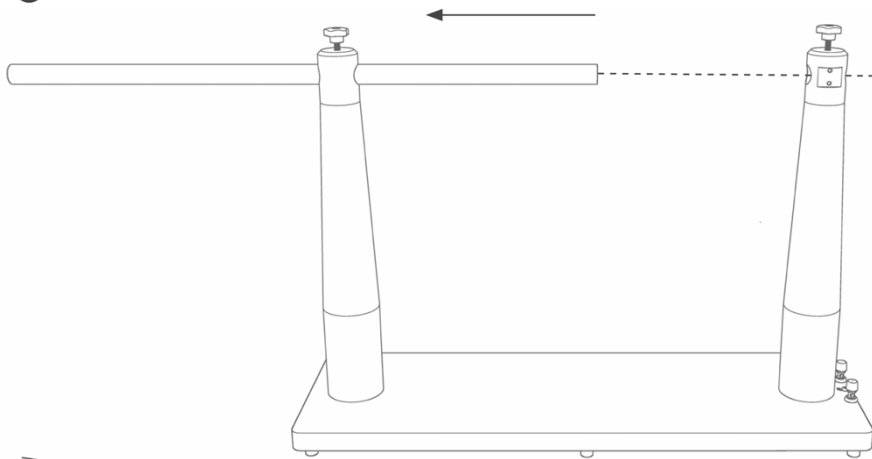

5

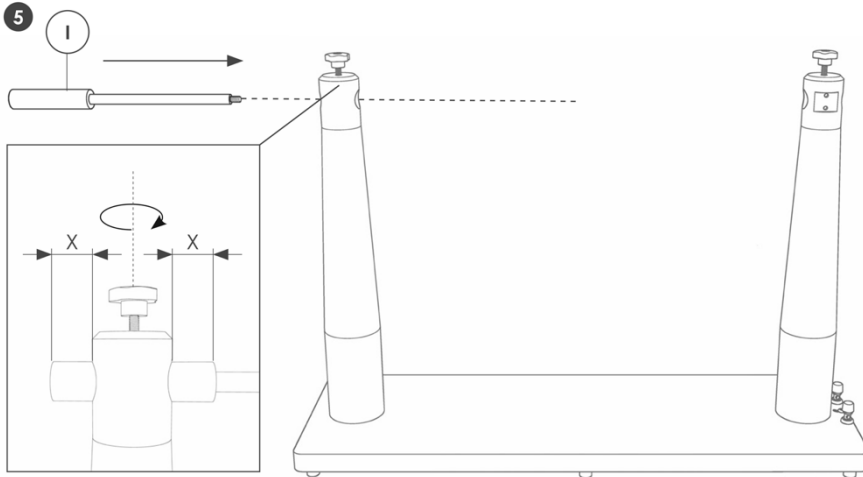

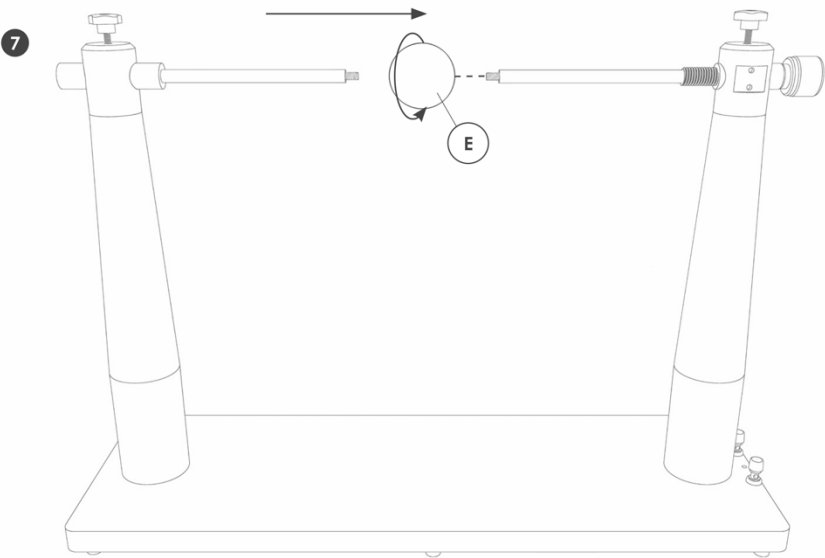
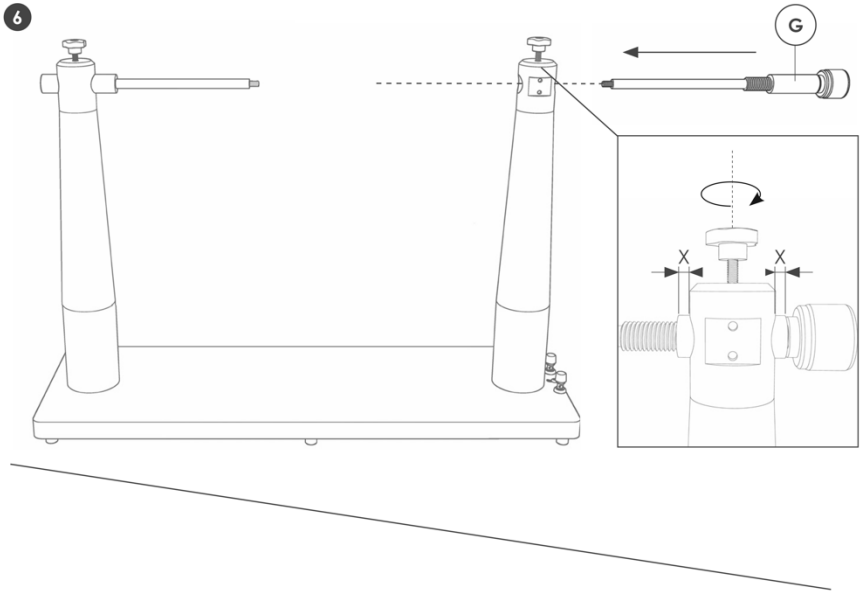

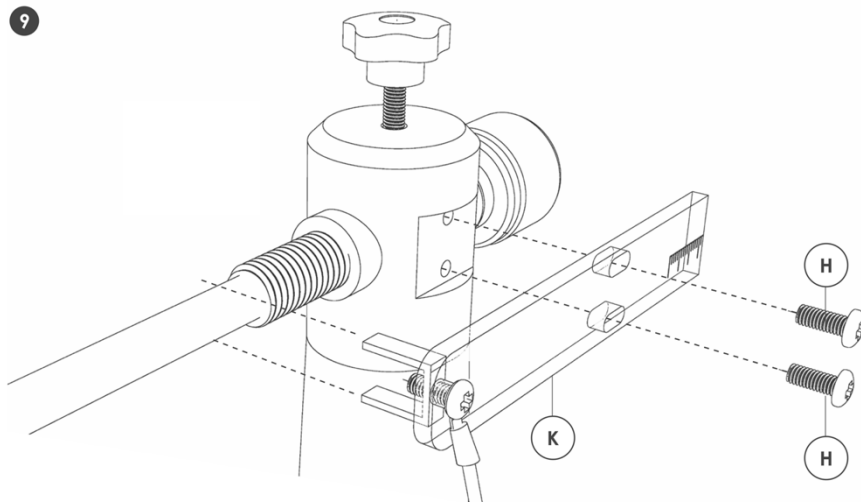
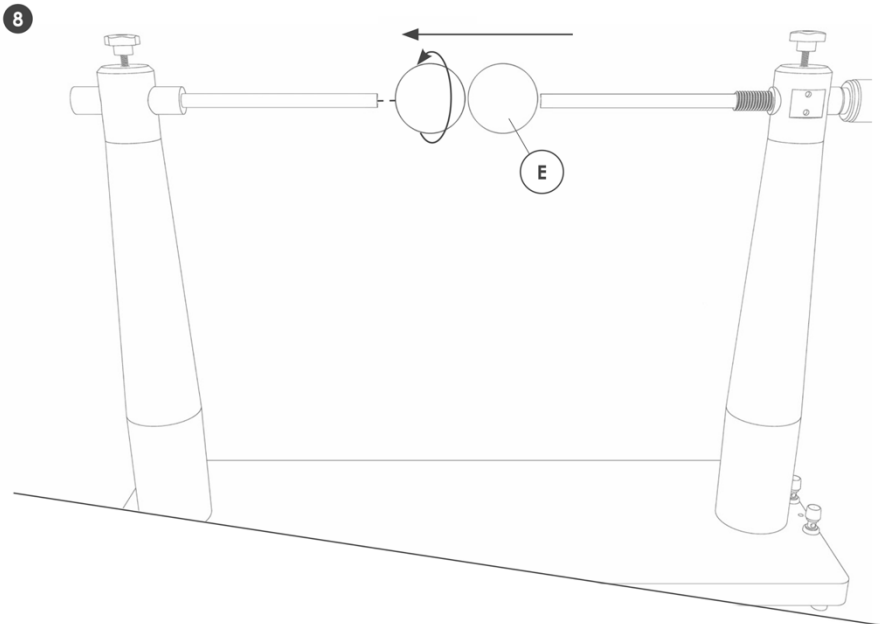

10

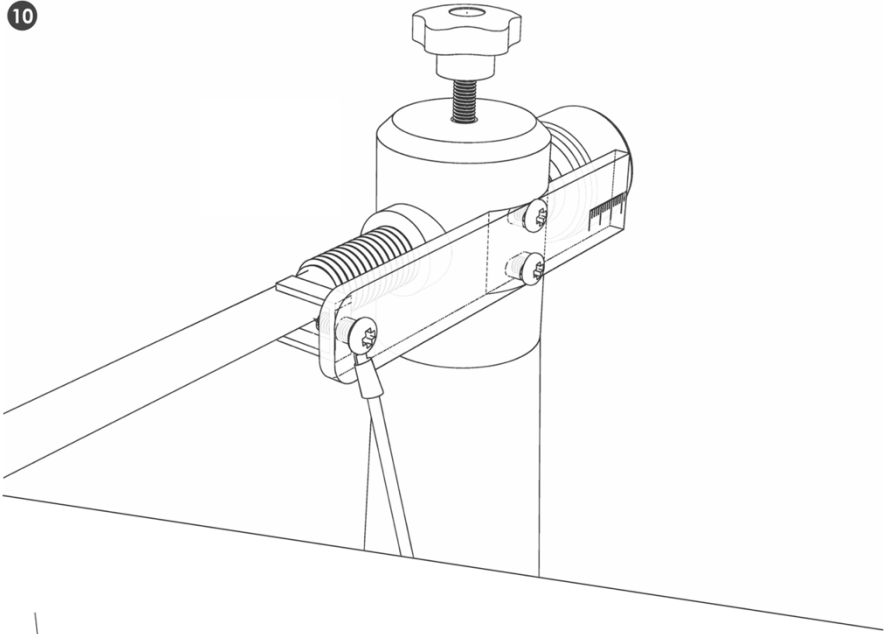

11

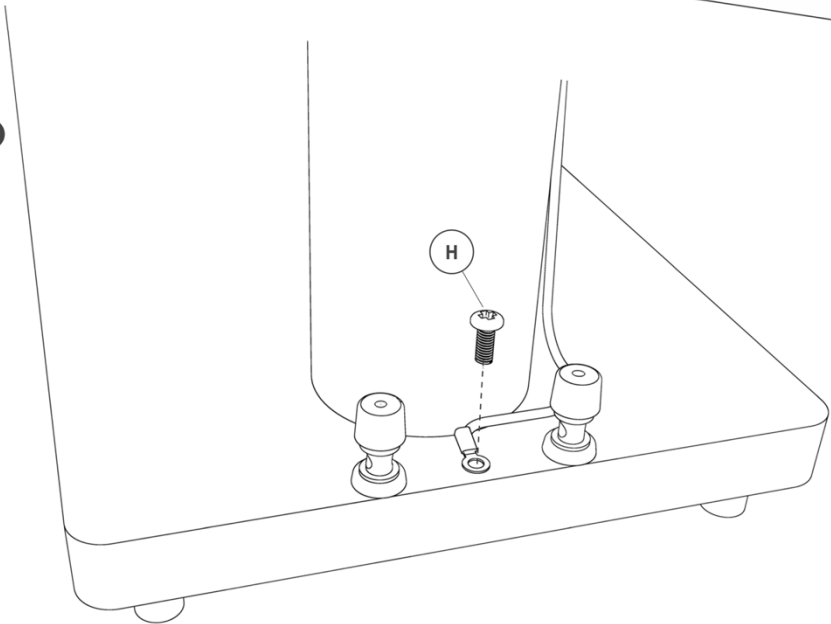

12

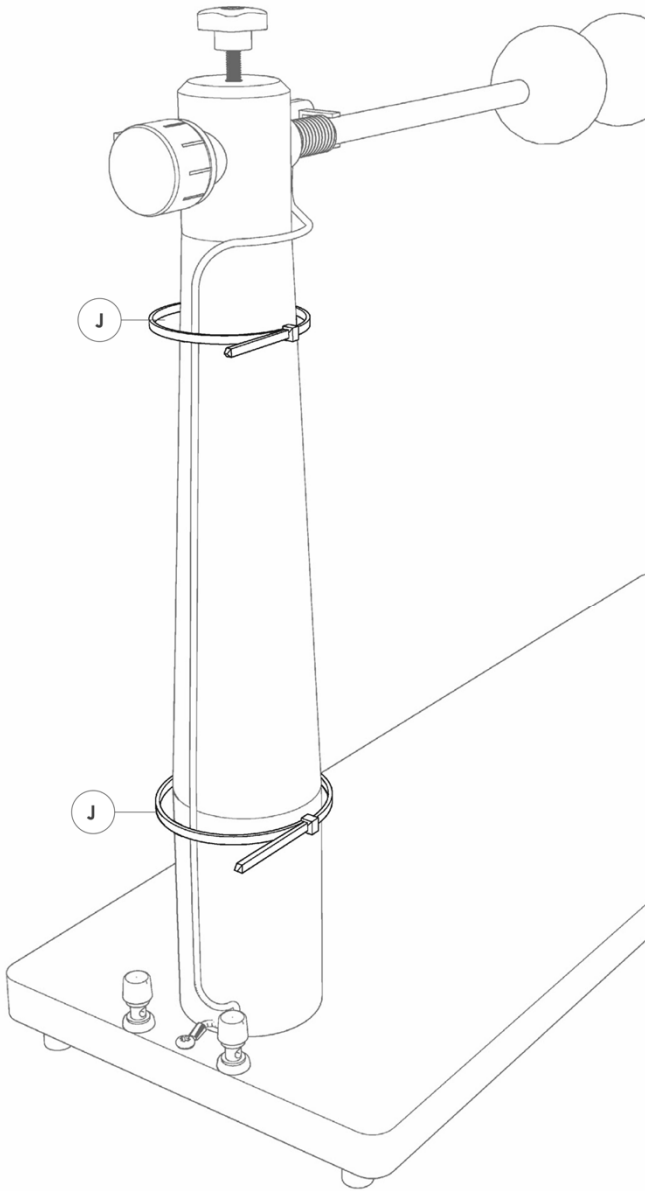

# Calibration

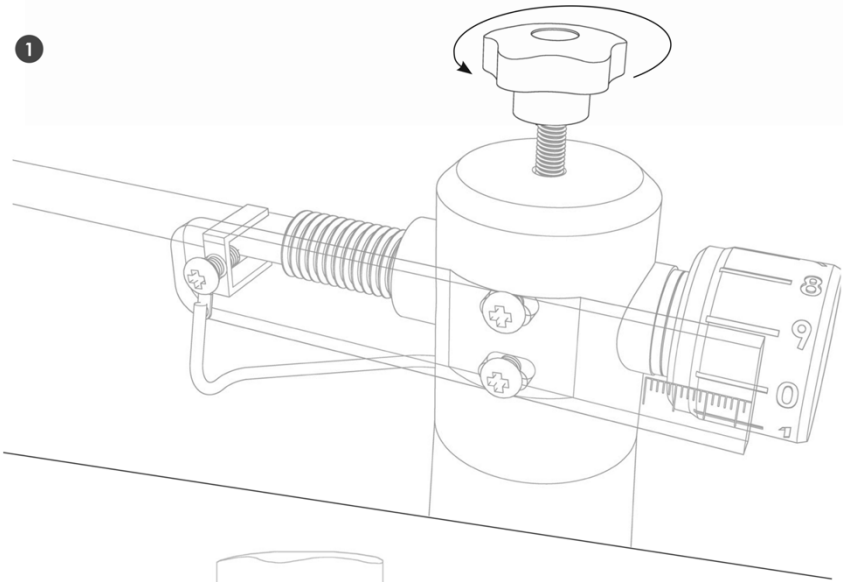
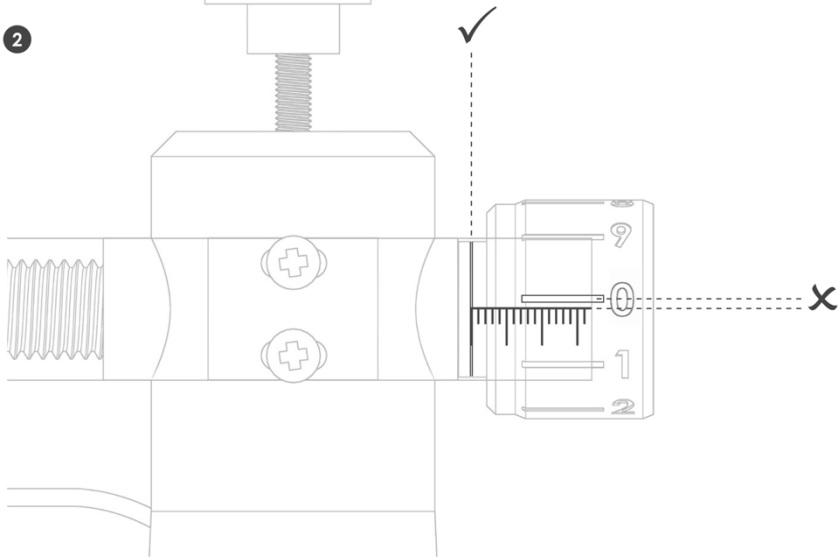
**1****2**

3

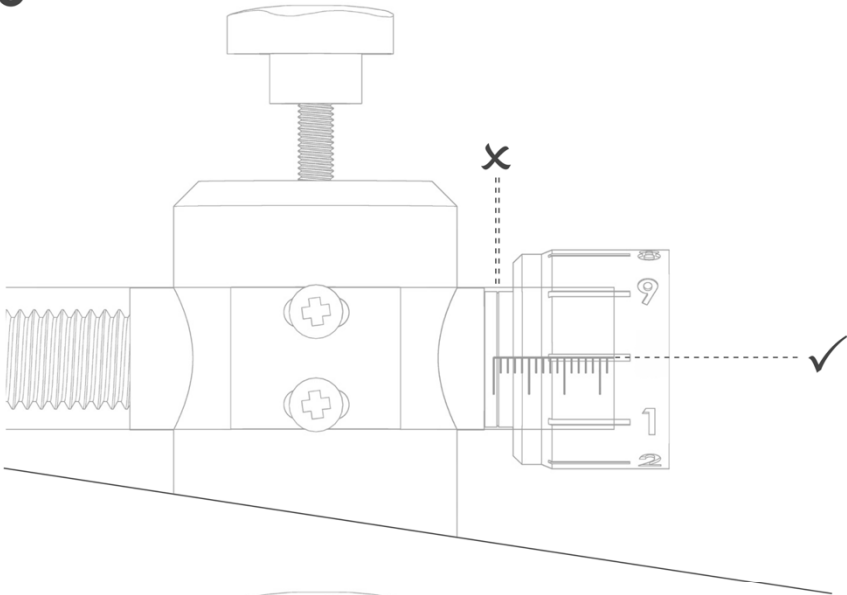

4

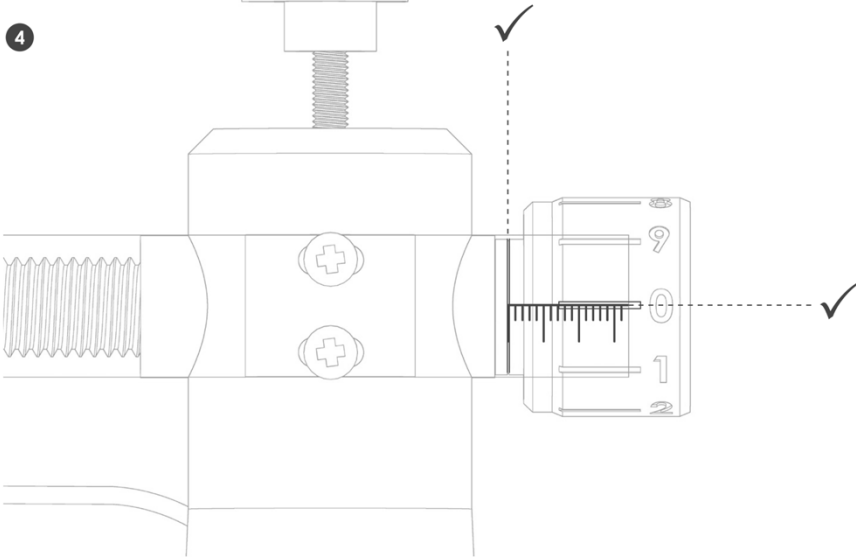



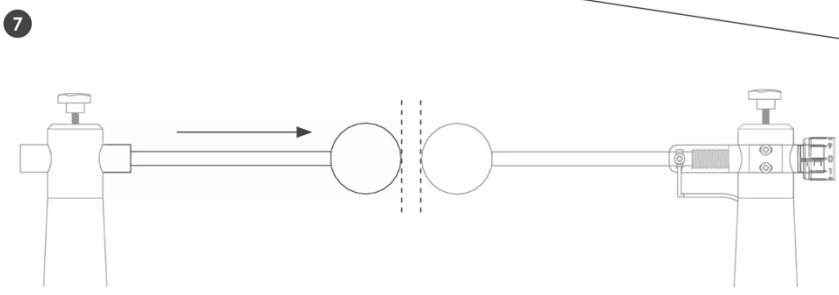
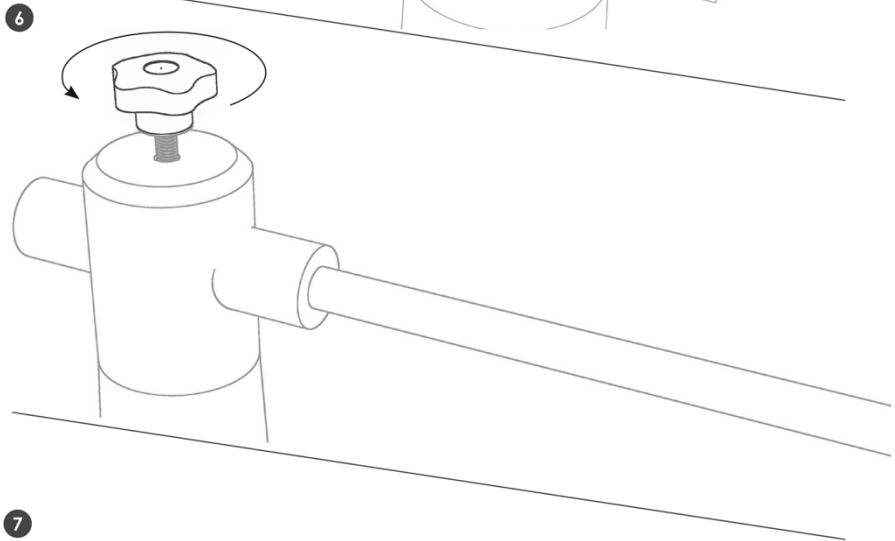
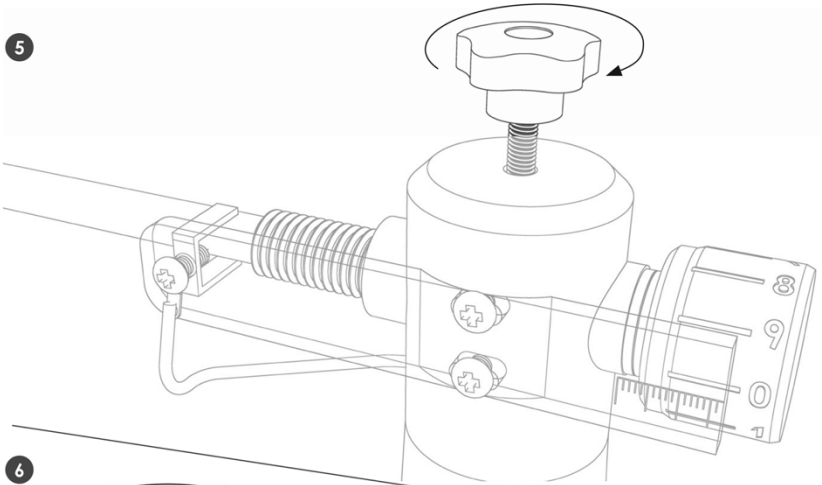

8a

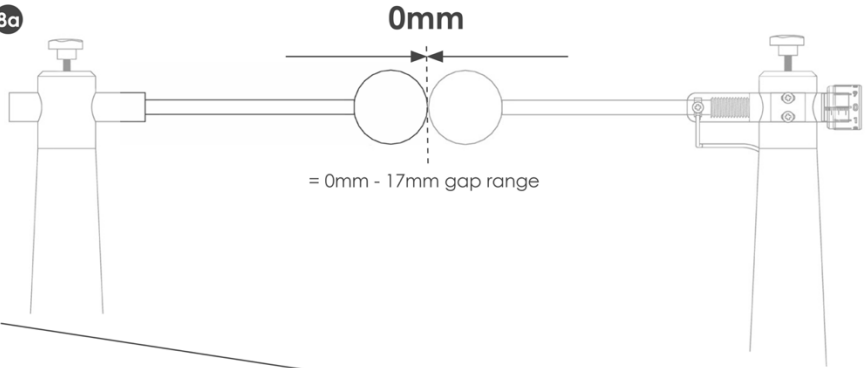

8b

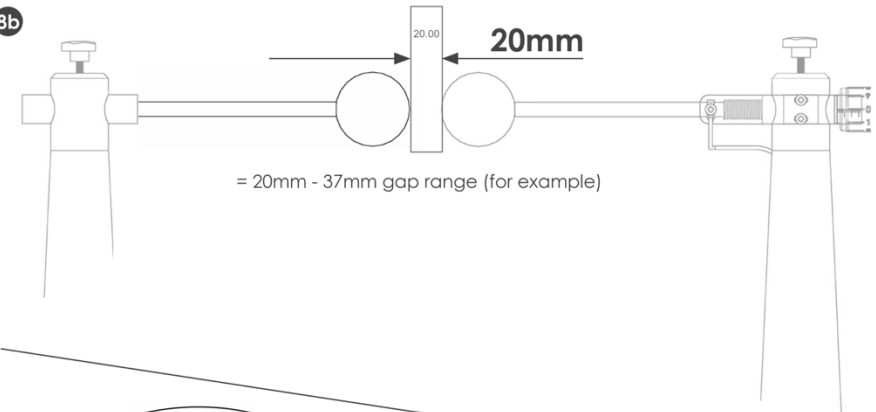

9

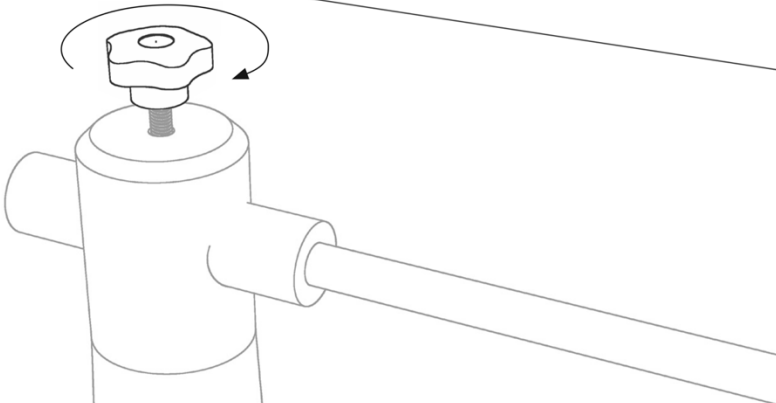

# Adjustment

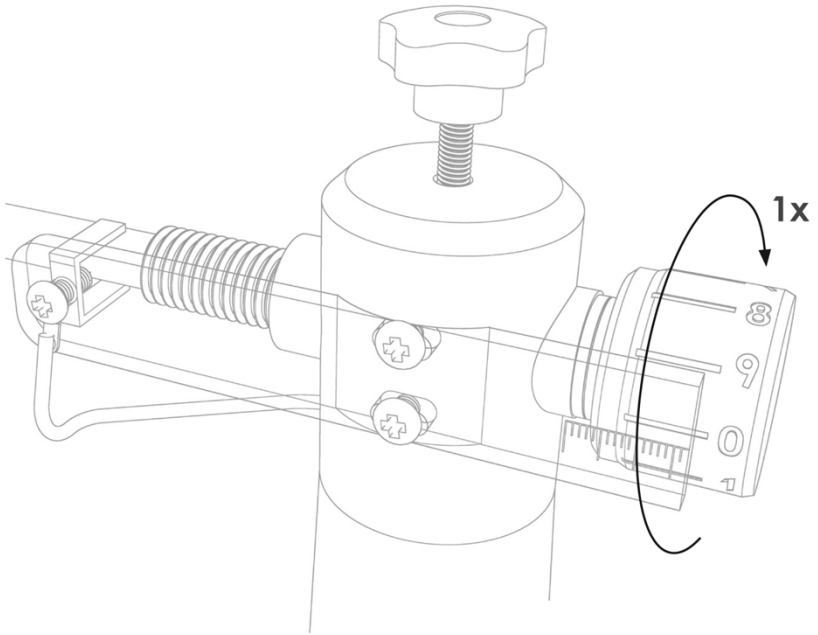
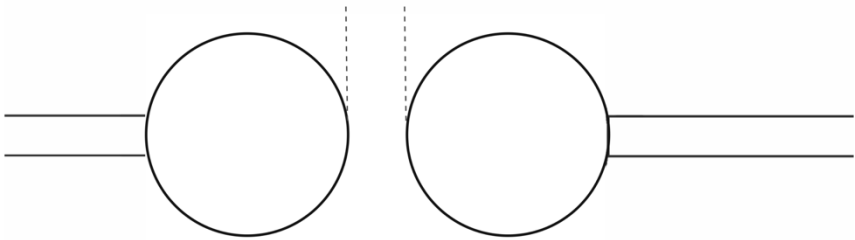
**1****= 1mm**

2

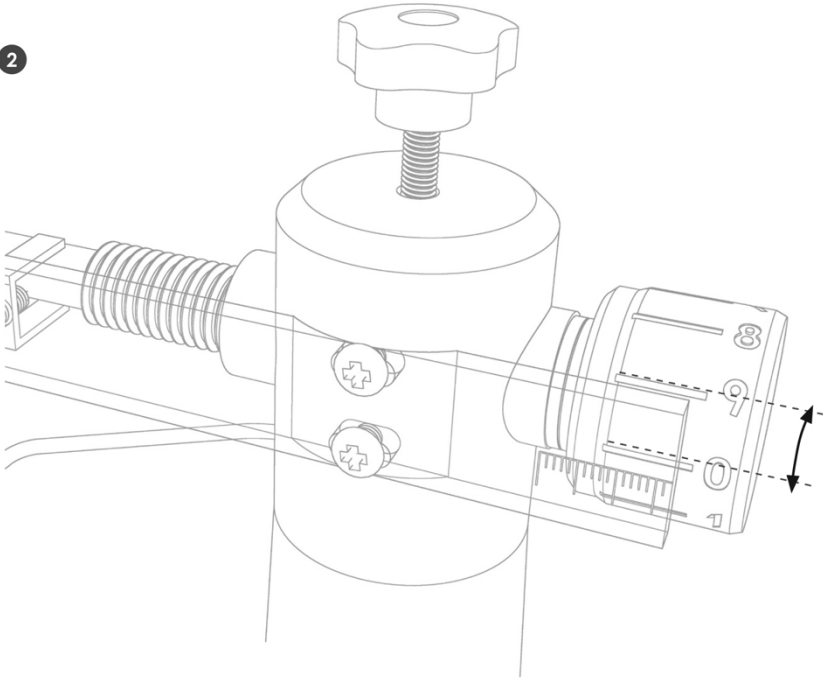

= 0.1mm

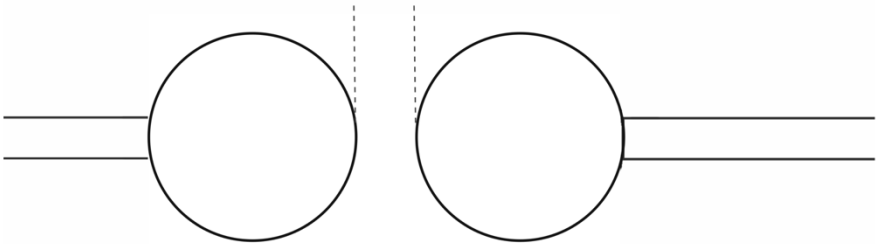

# Electrical Connection

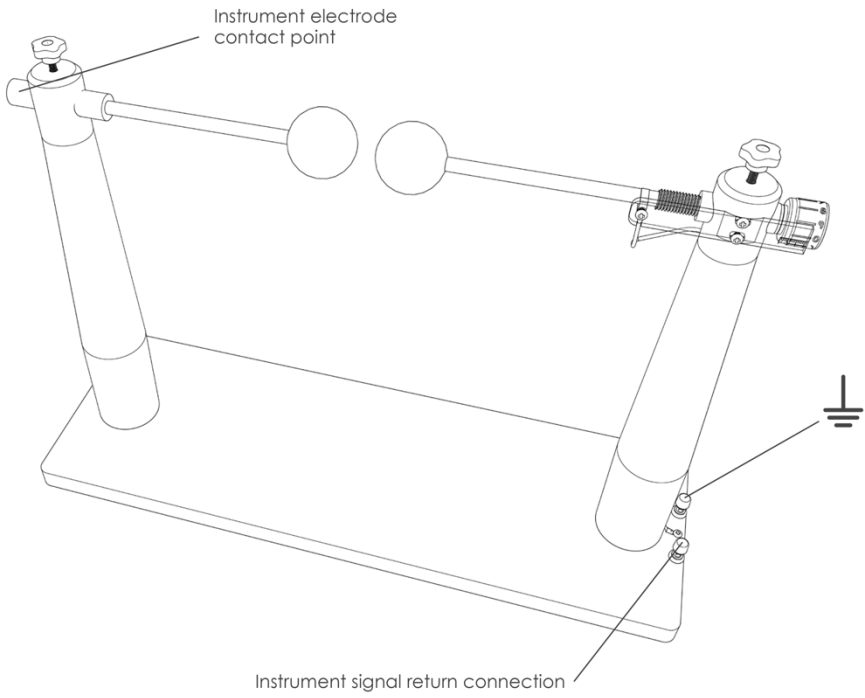

# Product Registration

**Thank you for choosing a Buckleys product, we are sure it will provide you with many years of reliable service.**

Please register this product via Buckleys' website and download the Warranty Registration Certificate.

**Register your product in 5 minutes.**

Once your product is registered, you will receive the following benefits:

- Latest industry news relating to your product
- Be the first to hear about our new products

**We strive to improve the quality of our products and service.**

Registering your product helps us monitor overall quality of our products, service and dealer network. Additionally, if we ever need to contact you regarding your product, we are able to do so immediately.

We will also send you annual service/ calibration reminders by email to help ensure your product is always in perfect working order.

To register your product, simply visit:

**[www.buckleysinternational.com/ registration](http://www.buckleysinternational.com/registration)**

... Complete the online form and click on SUBMIT.



# Manufacturer

**Manufacturer:** Buckleys (UVRAL) Ltd.

**Address:** Buckleys House  
Unit G, Concept Court,  
Shearway Business Park,  
Shearway Road Folkestone,  
Kent CT19 4RG, UK

**Tel:** +44 (0)1303 278888

**Email:** [sales@buckleys.co.uk](mailto:sales@buckleys.co.uk)

**Web:** [www.buckleysinternational.com](http://www.buckleysinternational.com)

# Distributor

